

GasO, 1550-C, Duplex, Piston Pump (Mud Pump)

- 74 horsepower 10" stroke continuous duty double acting duplex pump
- Rated at pump speeds up to 85 RPM
- Maximum discharge pressures up to 1400 psi
- Equipped with cast iron fluid ends
- Equipped with internal gear reduction unit

Specs

Spec	U.S. Standard
Type:	duplex
Minimum Piston Diameter:	2½"
Maximum Piston Diameter:	5"
Stroke length:	10"
Maximum Working Pressure:	1,320 PSI
Rod/Piston Load:	6520lb
Gallons per Minute:	282.0
Barrels per Day:	9669
Brake Horse Power:	58.5

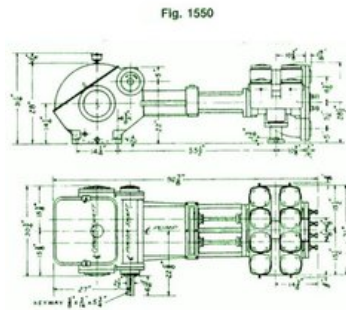

Features/Benefits

Power End Features

- Cast iron power frame
- Steel crankshaft
- Heavy-duty roller crankshaft bearings
- Bi-metal crankpin bearings
- Ductile iron connecting rods
- Allow steel crosshead pins
- Bronze bearing crosshead pin bushings

Internal gear reduction / 5.920:1 Ratio / with:

- Ductile iron herringbone type main gear
- Allow steel pinion shaft with herringbone pinion gear
- Heavy-duty roller pinion shaft bearings
- Flooded sump, splash distribution lubrication
- Cast iron crossheads with upper/lower oil grooves
- Rated rod load is 7475 lbs.

Fluid End Features

- Bolted Valve and cylinder head covers
- Bolted or threaded type glands & removable stuffing boxes
- File Hard Steel Piston Rods
- Standard Valve Types:
 - For crude oil transfer:
 - Steel wing guided valve & seat
 - For slush / mud service:
 - Steel wing guided with replaceable insert
- Standard Piston Types:
 - For crude oil transfer:
 - Cast iron piston body, ring type

- Cast iron, chrome faced, piston rings
- For slush / mud service:
 - Mission mud type piston w/replaceable rubbers
 - General service rod packing

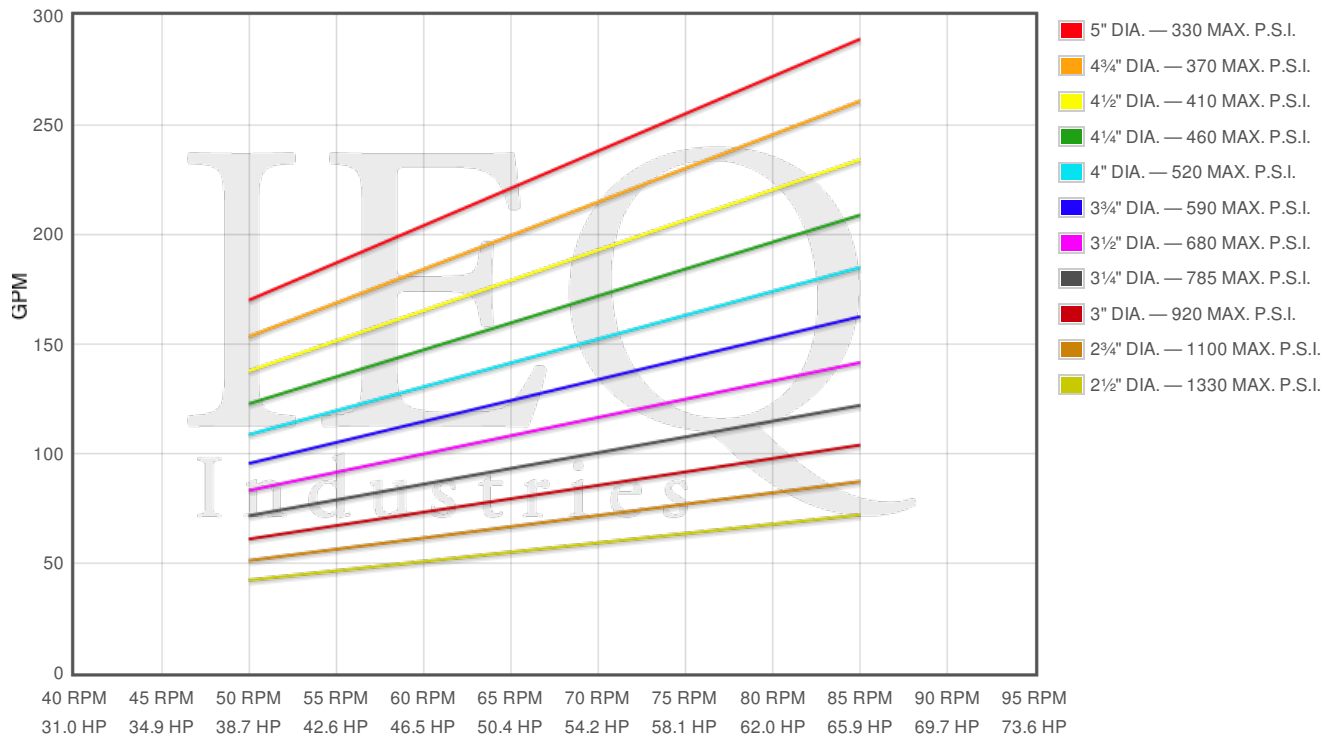

Pump	English Units					50 RPM		60 RPM		70 RPM		80 RPM		85 RPM	
	Plunger Dia. In.	Plunger Area Sq. In.	BPD per RPM	GPM per RPM	Max Press. PSI	BPD	GPM	BPD	GPM	BPD	GPM	BPD	GPM	BPD	GPM
1550-C	5.000	19.6350	116.571	3.4000	332	5829	170.0	6994	204.0	8160	238.0	9326	272.0	9909	289.0
	4.750	17.7205	105.205	3.0685	368	5260	153.4	6312	184.1	7364	214.8	8416	245.5	8942	260.8
	4.500	15.9043	94.423	2.7540	410	4721	137.7	5665	165.2	6610	192.8	7554	220.3	8026	234.1
	4.250	14.1863	84.223	2.4565	460	4211	122.8	5053	147.4	5896	172.0	6738	196.5	7159	208.8
	4.000	12.5664	74.606	2.1760	519	3730	108.8	4476	130.6	5222	152.3	5968	174.1	6341	185.0
	3.750	11.0447	65.571	1.9125	590	3279	95.62	3934	114.7	4590	133.9	5246	153.0	5574	162.6
	3.500	9.6211	57.120	1.6660	678	2856	83.3	3427	99.96	3998	116.6	4570	133.3	4855	141.6
	3.250	8.2958	49.251	1.4365	786	2463	71.82	2955	86.19	3448	100.6	3940	114.9	4186	122.1
	3.000	7.0686	41.966	1.2240	922	2098	61.2	2518	73.44	2938	85.68	3357	97.92	3567	104.0
	2.750	5.9396	35.263	1.0285	1098	1763	51.42	2116	61.71	2468	71.99	2821	82.28	2997	87.42
	2.500	4.9087	29.143	0.8500	1328	1457	42.5	1749	51.0	2040	59.5	2331	68.0	2477	72.25

Disclaimer I

This website is intended as a reference tool only. It has been constructed from published data that is based on manufacturer's sales and engineering documents that are either current, historical and obsolete. Much of the machinery data contained herein has been re-rated through the years with different engineering criteria which maybe in conflict with legacy data. Much of the content published here is calculated online with the use of dynamic data using formulas and extrapolations considered to be sound engineering formulas and are correct to the degree that the data used is accurate. We have done our best to be as precise as as possible in this posting but do not represent any of the calculations or performance data to be entirely accurate. The data published here is intended to be general information rather than actual and to serve as a reference rather than a technical absolute. The user of such data should confirm such information independently.

Copyright and Disclaimers

WheatleyGasO.com is your resource for Gaso pumps, Gaso pump parts and a supplier of ORIGINAL GASO PARTS and equipment, new used and remanufactured Wheatley, GASO and

