

Wheatley, P50-ALS (5S-2L), Simplex, Plunger Pump

Pumps in this series

[P50-A \(5S-2M\)](#)

[P50-ALS \(5S-2L\)](#)

[P50-B \(2S-1M\)](#)

[P50-BH \(2S-1H\)](#)

[P50-BLS \(2S-1L\)](#)

[P50-H \(5S-2H\)](#)

- 5 horsepower 2.188" stroke horizontal simplex single acting plunger pump
- Available in four different fluid end materials
- Pump speeds up to 350 RPM

Specs

Spec	U.S. Standard
Type:	simplex
Minimum Plunger Diameter:	1 1/2"
Maximum Plunger Diameter:	2"
Stroke length:	2 3/16"
Maximum Working Pressure:	1,149 PSI
Rod/Piston Load:	2030lb
Gallons per Minute:	10.41
Barrels per Day:	357
Brake Horse Power:	5.5

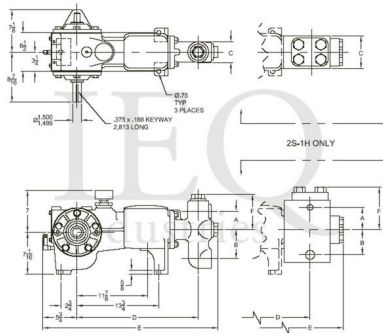

Pump Curves

Hover over Power Curves to reveal RPM and GPM

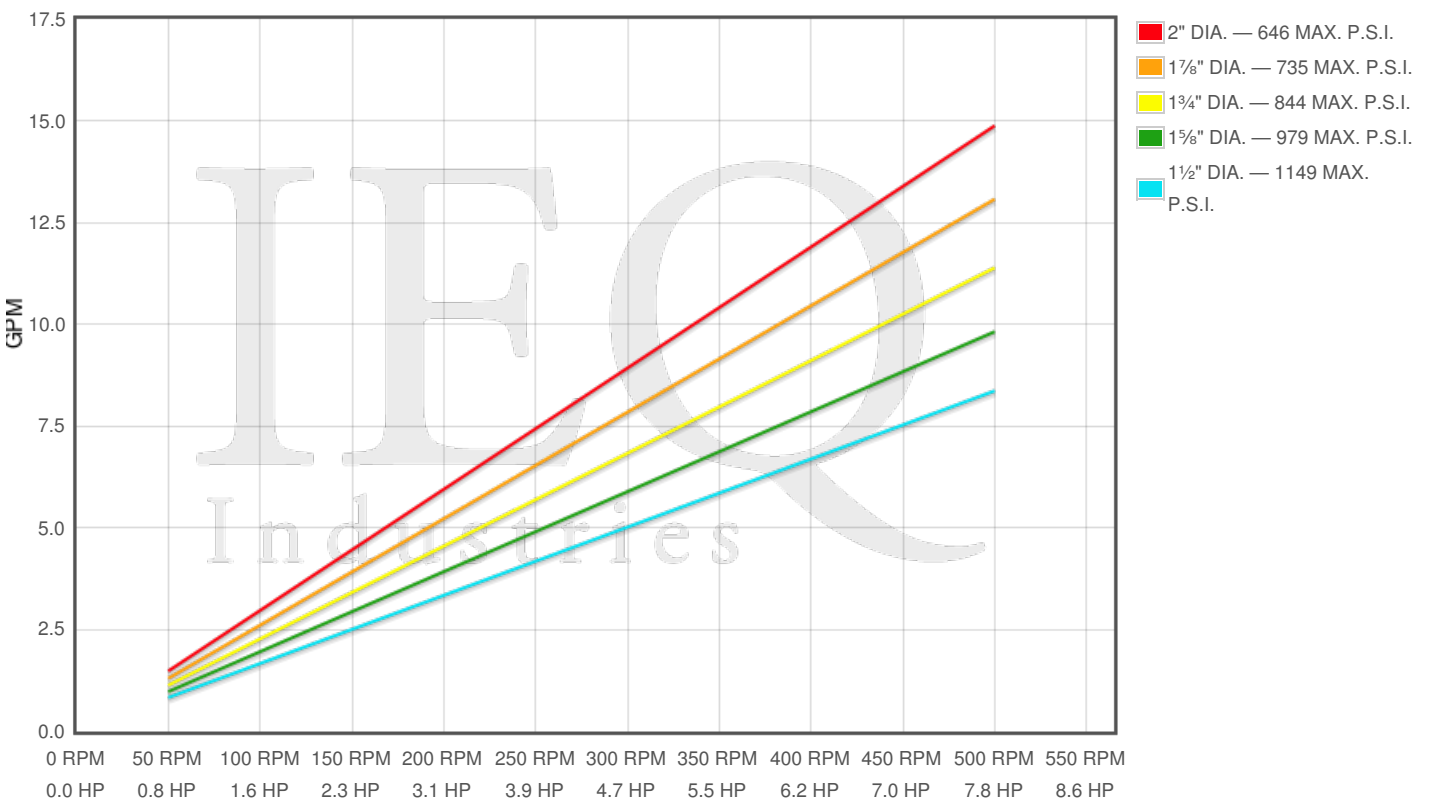

Performance Data Table

Pump	Plunger Dia. In.	Plunger Area Sq. In.	English Units			50 RPM		200 RPM		350 RPM		500 RPM	
			BPD per RPM	GPM per RPM	Max Press. PSI	BPD	GPM	BPD	GPM	BPD	GPM	BPD	GPM
P50-ALS 5S-2L	2.000	3.1416	1.020	0.0297	646	51	1	204	6	357	10	510	15
	1.875	2.7612	0.896	0.0261	735	45	1	179	5	314	9	448	13
	1.750	2.4053	0.781	0.0228	844	39	1	156	5	273	8	390	11
	1.625	2.0739	0.673	0.0196	979	34	1	135	4	236	7	337	10
	1.500	1.7671	0.574	0.0167	1149	29	1	115	3	201	6	287	8

Features/Benefits

Power End Features:

- Cast iron power frame
- Alloy steel crosshead pins
- Heavy-duty roller crankshaft bearings
- Precision type, aluminum alloy crankpin bearings
- Cast iron connecting rods
- Ductile Iron crankshaft with ground journals & polished throws
- Bronze bearing crosshead pin bushings
- Cast iron crossheads with upper/lower oil grooves
- One piece plungers
- Flooded sump, splash distribution lubrication
- Rated rod load is 2030 lbs

Fluid End Features:

- Bolted Covers forged Liquid Ends
- Threaded type glands & integral stuffing boxes
- Bronze stuffing box bushings and packing followers
- Optional flanged connections available
- Abrasion Resistant Valves
- Plungers - Solid Ceramic, or Tungsten Coated
- Spring loaded Plunger Packing

Disclaimer I

This website is intended as a reference tool only. It has been constructed from published data that is based on manufacturer's sales and engineering documents that are either current, historical and obsolete. Much of the machinery data contained herein has been re-rated through the years with different engineering criteria which maybe in conflict with legacy data. Much of the content published here is calculated online with the use of dynamic data using formulas and extrapolations considered to be sound engineering formulas and are correct to the degree that the data used is accurate. We have done our best to be as precise as as possible in this posting but do not represent any of the calculations or performance data to be entirely accurate. The data published here is intended to be general information rather than actual and to serve as a reference rather than a technical absolute. The user of such data should confirm such information independently.

Copyright and Disclaimers

WheatleyGas.com is your resource for Gaso pumps, Gaso pump parts and a supplier of ORIGINAL GASO PARTS and equipment, new used and remanufactured Wheatley, GASO and Wheatley/GASO plunger and piston pumps and pump parts and is not affiliated with Wheatley/GASO Inc. or its parent company, National Oilwell Varco, Copyright ©2024 IEQ Industries, a Gallagher Fluid Handling Company. All rights reserved, *Used under license from IntelleQ Holdings, LLC.