

## Gaso, 1742, Duplex, Piston Pump (Mud Pump)

### Pumps in this series

- [1740](#)
- [1741](#)
- [1742](#)
- [1743](#)

### Specs

Spec	U.S. Standard
Type:	duplex
Minimum Piston Diameter:	2½"
Maximum Piston Diameter:	5½"
Stroke length:	10"
Maximum Working Pressure:	1,440 PSI
Rod/Piston Load:	13100lb
Gallons per Minute:	336.8
Barrels per Day:	11547
Brake Horse Power:	119.1

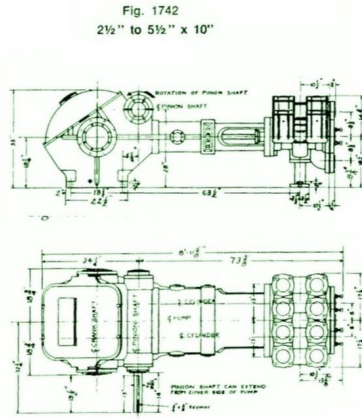

### Pump Curves

Hover over Power Curves to reveal RPM and GPM

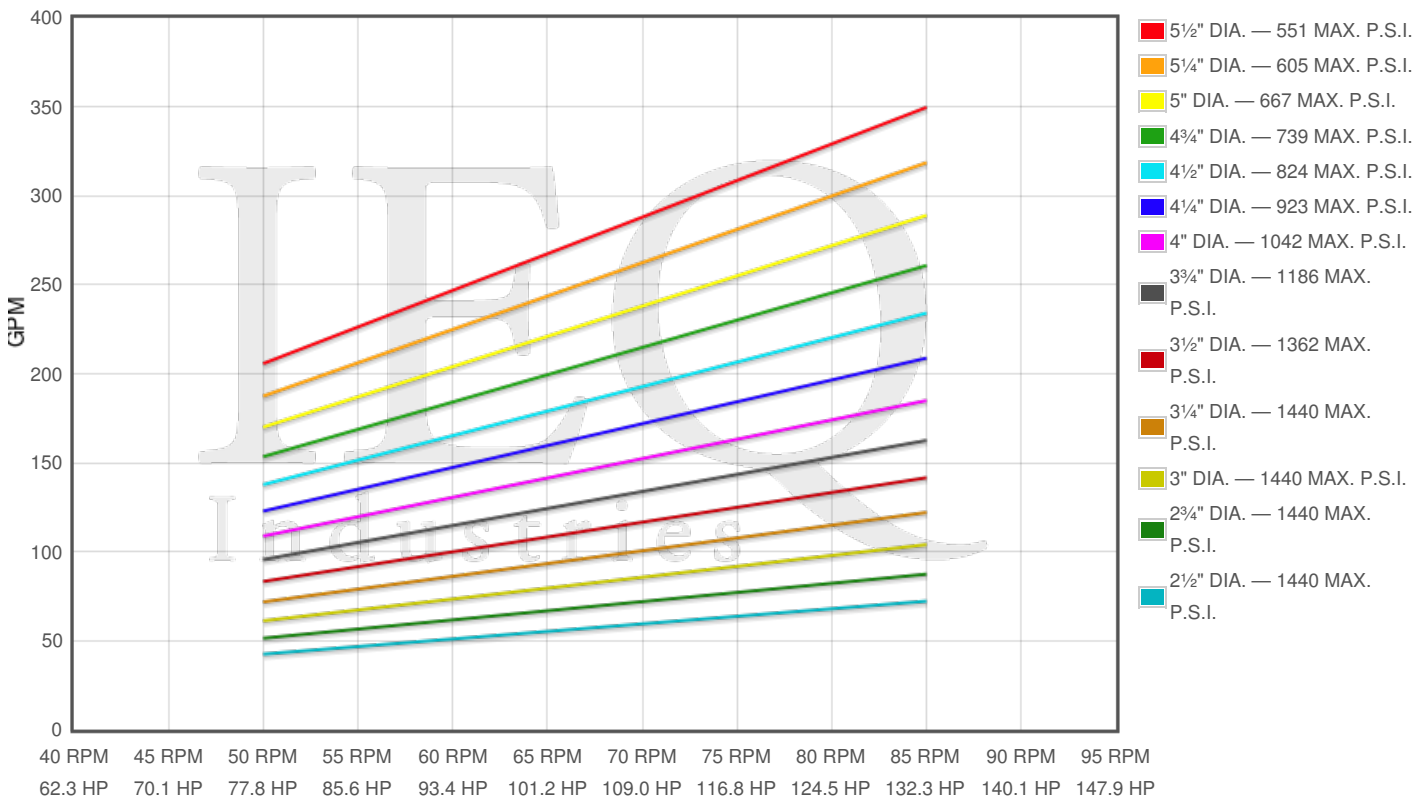

### Performance Data Table

Pump	English Units					50 RPM		60 RPM		70 RPM		80 RPM		85 RPM	
	Plunger Dia. In.	Plunger Area Sq. In.	BPD per RPM	GPM per RPM	Max Press. PSI	BPD	GPM	BPD	GPM	BPD	GPM	BPD	GPM	BPD	GPM
1742	5.500	23.7583	141.051	4.1140	551	7053	206	8463	247	9874	288	11284	329	11989	350
	5.000	19.6350	116.571	3.4000	667	5829	170	6994	204	8160	238	9326	272	9909	289
	4.500	15.9043	94.423	2.7540	824	4721	138	5665	165	6610	193	7554	220	8026	234
	4.000	12.5664	74.606	2.1760	1042	3730	109	4476	131	5222	152	5968	174	6342	185
	3.500	9.6211	57.120	1.6660	1362	2856	83	3427	100	3998	117	4570	133	4855	142
	3.000	7.0686	41.966	1.2240	1440	2098	61	2518	73	2938	86	3357	98	3567	104
	2.500	4.9087	29.143	0.8500	1440	1457	42	1749	51	2040	59	2331	68	2477	72

### Features/Benefits

---

## GASO DUPLEX PISTON PUMPS

Ratings published here in are intended to be used only for preliminary planning purposes, and as such carried no warranties whatsoever. All applications for gas opines must be approved in writing. THE INFORMATION CONTAINED HERE IS TRANSCRIBED FROM A GASO TECHNICAL MANUAL FROM THE 1960s - 70s. IEQ INDUSTRIES OR THE CUSTODIANS OF THIS WEBSITE ARE NOT RESPONSIBLE FOR ITS CONTENT.

### Power End Specifications

*Power Frame.* High-strength gray iron alloy casting with heavy wall sections, well ribbed to ensure rigid construction and design to fully enclose all working parts.

*Gears.* Continuous to Sykes herringbone construction. Main gear is heat treated high-grade ductile iron. Pinion gear is cut from forged alloy steel and hardened.

*Crankshaft.* Have a center section for mounting main gear. Large diameter crank pins

*Pinion Shaft.* Alloy steel bar stock, machine and precision ground.

*Bearings.* Heavy duty tapered roller bearings on crankshaft. Self-contained double roll bearings on pinion shaft to permit free floating of shaft for self centering of peers.

*Connecting Rods.* Heavy cross section castings with renewable Babbitt lined steel shell bearings and crank and; bronze bushing in cross head end.

*Lubrication.* All power and parts including gears, cross heads, connecting rod bearings, crankshaft bearings and pinion crank shaft bearings, are lubricated by splash system from lubricant in crankcase reservoir.

### Fluid End Specifications

*Power Frame.* Alloys stocked are Molybdenum cast iron and cast steel. Fluid ounce can be trimmed out for pumping various liquids. Ductile iron can be furnished upon request.

*Cylinder Heads.* Heavy section alloy casting to match material of pump fluid body.

*Valve Covers.* Heavy section alloy casting to match material of pump fluid body.

*Liners.* All pumps are available with interchangeable pipe liners. Standard materials available are Molybdenums alloyed iron, file hard steel and special corrosion resistant liners.

*Piston Rods.* Various rod materials are available. These are: steel, bronze, stainless steel, file hard steel, and chrome plated steel.

*Pistons.* Molly iron and bronze bodies fitted with various types of rings or cups are available. slush service pistons can also be furnished.

*Valves.* Valves and seats are available as follows: hardened and ground steel wing guided, bronze wing guided, steal or bronze insert type, direct blood valves for use on cast iron or bronze seats. McClatchie and mission can also be furnished.

*Stuffing Boxes.* All duplex pumps are furnished with replaceable type stuffing boxes which are available in cast iron and bronze.

*Packing.* Standard packing is a set of lip type packing rings. Other packings can be furnished for special applications.

*Stuffing Box Lubrication.* Furnished by use of regulated flow of oil from a force-feed lubricate or mounted on the pump, with a separate oil line to each stuffing box.

### Disclaimer I

---

This website is intended as a reference tool only. It has been constructed from published data that is based on manufacturer's sales and engineering documents that are either current, historical and obsolete. Much of the machinery data contained herein has been re-rated through the years with different engineering criteria which maybe in conflict with legacy data. Much of the content published here is calculated online with the use of dynamic data using formulas and extrapolations considered to be sound engineering formulas and are correct to the degree that the data used is accurate. We have done our best to be as precise as as possible in this posting but do not represent any of the calculations or performance data to be entirely accurate. The data published here is intended to be general information rather than actual and to serve as a reference rather than a technical absolute. The user of such data should confirm such information independently.

---

### Copyright and Disclaimers

WheatleyGas.com is your resource for Gaso pumps, Gaso pump parts and a supplier of ORIGINAL GASO PARTS and equipment, new used and remanufactured Wheatley, GASO and Wheatley/GASO plunger and piston pumps and pump parts and is not affiliated with Wheatley/GASO Inc. or its parent company, National Oilwell Varco, Copyright ©2024 IEQ Industries, a Gallagher Fluid Handling Company. All rights reserved, \*Used under license from IntelleQ Holdings, LLC.