

Gaso, 1753, Duplex, Piston Pump (Mud Pump)

Pumps in this series

- [1753](#)
- [1755](#)
- [1757](#)
- [1759](#)

Specs

Spec	U.S. Standard
Type:	duplex
Minimum Piston Diameter:	4"
Maximum Piston Diameter:	7½"
Stroke length:	10"
Maximum Working Pressure:	1,040 PSI
Rod/Piston Load:	13100lb
Gallons per Minute:	637.2
Barrels per Day:	21847
Brake Horse Power:	121.0

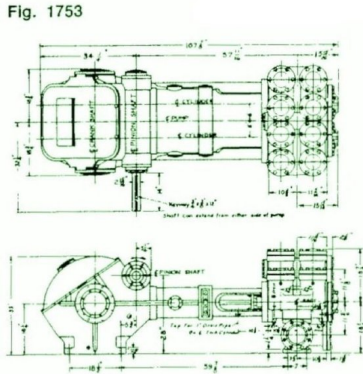

Pump Curves

Hover over Power Curves to reveal RPM and GPM

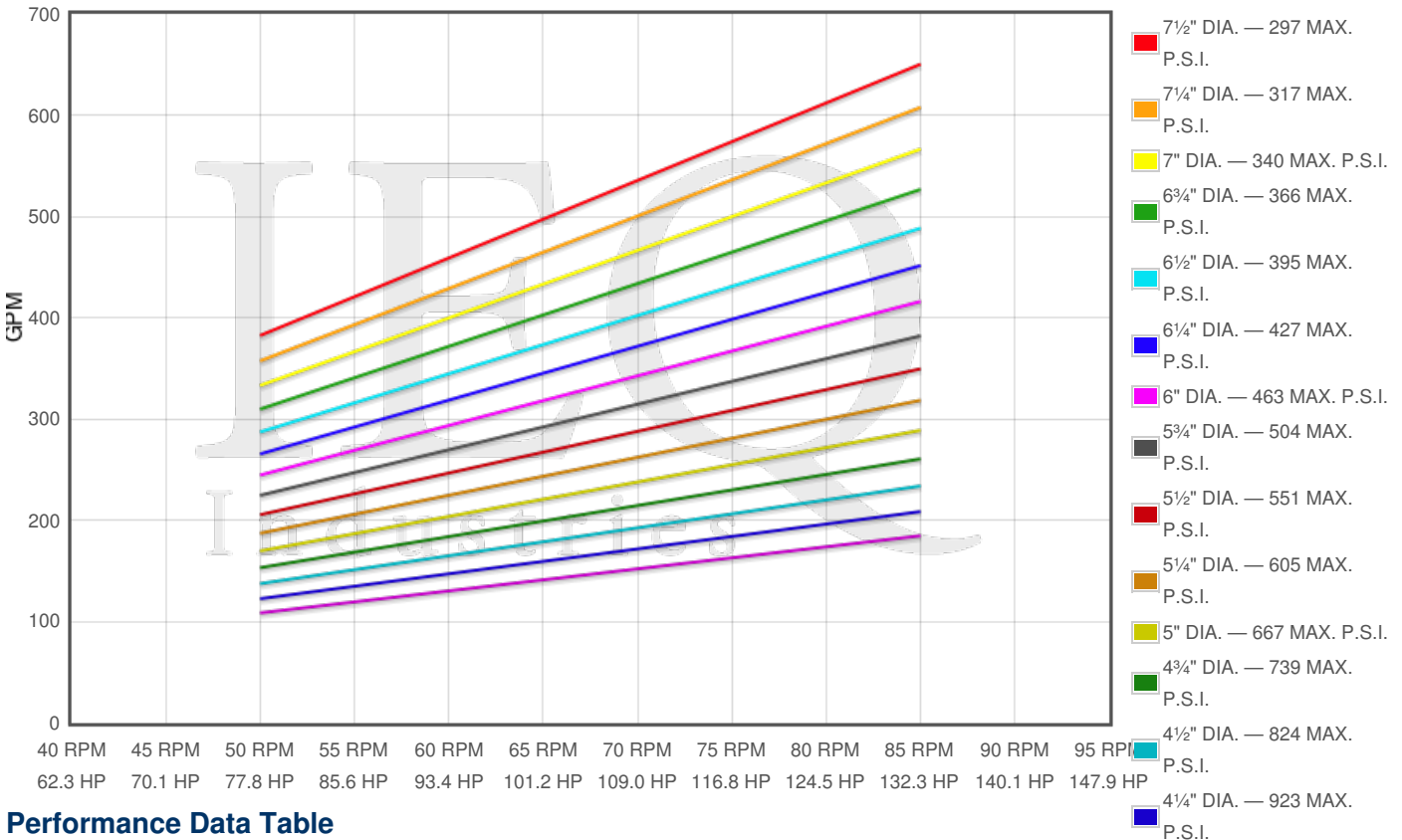

Performance Data Table

Pump	English Units					50 RPM		60 RPM		70 RPM		80 RPM		85 RPM	
	Plunger Dia. In.	Plunger Area Sq. In.	BPD per RPM	GPM per RPM	Max Press. PSI	BPD	GPM	BPD	GPM	BPD	GPM	BPD	GPM	BPD	GPM
1753	7.500	44.1786	262.285	7.6500	297	13114	382	15737	459	18360	535	20983	612	22294	650
	7.000	38.4845	228.479	6.6640	340	11424	333	13709	400	15994	466	18278	533	19421	566
	6.500	33.1831	197.005	5.7460	395	9850	287	11820	345	13790	402	15760	460	16745	488
	6.000	28.2743	167.862	4.8960	463	8393	245	10072	294	11750	343	13429	392	14268	416
	5.500	23.7583	141.051	4.1140	551	7053	206	8463	247	9874	288	11284	329	11989	350
	5.000	19.6350	116.571	3.4000	667	5829	170	6994	204	8160	238	9326	272	9909	289
	4.500	15.9043	94.423	2.7540	824	4721	138	5665	165	6610	193	7554	220	8026	234
	4.000	12.5664	74.606	2.1760	1040	3730	109	4476	131	5222	152	5968	174	6342	185

Features/Benefits

Power End Features:

- Cast iron power frame
- Steel crankshaft
- Bi-metal crankpin bearings
- Ductile iron connecting rods
- Heavy-duty roller crankshaft bearings
- Alloy steel crosshead pins
- Bronze bearing crosshead pin bushings

- Internal gear reduction / 5.846:1/Ratio/ with:
 - Ductile iron herringbone type main gear
 - Allow steel pinion shaft with herringbone pinion gear
 - Heavy-duty roller pinion shaft bearings
- Flooded sump, splash distribution and lubrication
- Cast iron crossheads with upper/lower oil grooves
- Rated rod load is 131000 lbs.

Fluid End Features:

- Bolted Valve and Cylinder head covers
- Bolted or threaded type glands & removable stuffing boxes
- File hard steel piston rods
- Standard valve types
 - For crude oil transfer:
 - Steel wing guided valve & seat
 - For slush / mud service:
 - Steel wing guided with replaceable insert
- Standard Valve Types:
 - For crude oil transfer:
 - Cast iron piston body, ring type
 - Cast iron, chrome faced, piston rings
 - For slush / mud service:
 - Mission slush type piston w/ replaceable rubbers
- General service piston rod packing

Disclaimer I

This website is intended as a reference tool only. It has been constructed from published data that is based on manufacturer's sales and engineering documents that are either current, historical and obsolete. Much of the machinery data contained herein has been re-rated through the years with different engineering criteria which may be in conflict with legacy data. Much of the content published here is calculated online with the use of dynamic data using formulas and extrapolations considered to be sound engineering formulas and are correct to the degree that the data used is accurate. We have done our best to be as precise as possible in this posting but do not represent any of the calculations or performance data to be entirely accurate. The data published here is intended to be general information rather than actual and to serve as a reference rather than a technical absolute. The user of such data should confirm such information independently.

Copyright and Disclaimers

WheatleyGas.com is your resource for Gaso pumps, Gaso pump parts and a supplier of ORIGINAL GASO PARTS and equipment, new used and remanufactured Wheatley, GASO and Wheatley/GASO plunger and piston pumps and pump parts and is not affiliated with Wheatley/GASO Inc. or its parent company, National Oilwell Varco, Copyright ©2024 IEQ Industries, a Gallagher Fluid Handling Company. All rights reserved, *Used under license from IntelleQ Holdings, LLC.